

# Model 330LRT

## SCISSOR LIFTS



### MORE ECONOMIC

- Better Serviceability – Fully accessible hydraulic and engine compartments are easier to service

### MORE PRODUCTIVE

- Smoother Extension Deployment – New platform is designed to shed debris and allows smoother extension deployment

### MORE ACCESS

- Enhanced Stability on Uneven Surfaces – Standard oscillation gives you better traction and gradient climbing ability

### Standard Features

- 33/1550 x 16.5 foam filled loader lug tread tyres
- 1.79 m x 3.86 m steel platform (deck extension retracted)
- 1.14 m manual dual deck extension (Aluminium)
- Fold down handrails
- Dual side entry with half swing gates
- Lanyard attach points
- Proportional drive control with thumb steer
- Proportional lift/lower speed control
- Joystick enable for lift and drive
- Moveable and removable platform console box
- Load sensing system
- Programmable "Personality" settings
- On-board self-diagnostic testing
- Engine distress warning/shut down system<sup>1</sup>
- Hydrostatic drive with anti stall function
- Two speed drive selection
- Four wheel drive
- 3 degree tilt alarm and indicator light
- Oscillating front axle with DUS
- Lifting/tie down lugs
- Hour meter
- Ground control selector switch with key lock
- Lubrication free scissor arm bushings
- Scissor maintenance prop
- Horn
- Prepared for power connection in the platform
- Hydraulic levelling jacks

<sup>1</sup> Low oil pressure and high coolant temperature alarms with shut-down enabled/disabled by analyser.

### Standard Specifications

|                              |         |
|------------------------------|---------|
| Power Source                 |         |
| • Diesel Engine Kubota D1305 | 21.7 kW |
| • Fuel Tank Capacity         | 83 L    |
| Hydraulic System             | 122 L   |



### Accessories & Options

- 1.14 m manual single deck extension (Aluminium)\*
- 1.79 m x 4.82 m Megadeck steel platform (incl. dual platform extension of 1.16 m)
- IN315/55 D20 foam filled loader lug tread tyres
- 12 x 16.5 foam filled non mark tyres
- On-board 7500W generator
- Descent alarm
- All motion alarm
- 13 mm air line to platform
- Platform work lights
- Nite-Bright® package<sup>3</sup>
- Flashing amber beacon
- Plugs & Sockets
- Pipe positioners

<sup>3</sup> Includes four 50 W platform mounted halogen floodlights

\* When choosing the platform with one-sided extension, the platform capacity increases to 1,020 kg

# Model 330LRT

## SCISSOR LIFTS

### Performance

|  |                        |
|--|------------------------|
| • Working Height                         | 12.00 m                |
| Platform Height – Elevated               | 10.00 m                |
| A. Platform Height – Lowered             | 1.62 m                 |
| B. Platform Railing Height               | 1.10 m                 |
| C. Stowed Height (Rails Folded)          | 2.17 m                 |
| D. Platform Size                         | 1.79 m x 3.86 m        |
| Front Deck Extension                     | 1.16 m                 |
| Rear Deck Extension                      | 1.16 m                 |
| E. Overall Width                         | 2.35 m                 |
| F. Overall Length                        | 4.88 m                 |
| G. Wheelbase                             | 2.97 m                 |
| • Ground Clearance                       | 0.35 m                 |
| • Platform Capacity                      | 909 kg                 |
| • Capacity on Optional Deck Extension(s) | 230 kg                 |
| • Lift/Lower Time                        | 35/37 sec.             |
| • Maximum Drive Height                   | 10 m full drive height |
| • Machine weight <sup>1</sup>            | 5,614 kg               |
| • Maximum Ground Bearing Pressure        | 6.7 kg/cm <sup>2</sup> |
| • Drive Speed 4WD                        | 5.6 km/h               |
| • Gradeability 4WD                       | 45%                    |
| • Turning Radius – Inside                | 2.70 m                 |
| • Turning Radius – Outside               | 5.93 m                 |
| • Axle Oscillation                       | 0.20 m                 |

<sup>1</sup> Certain options or country standards may increase weight and/or dimensions.

### Dimensions

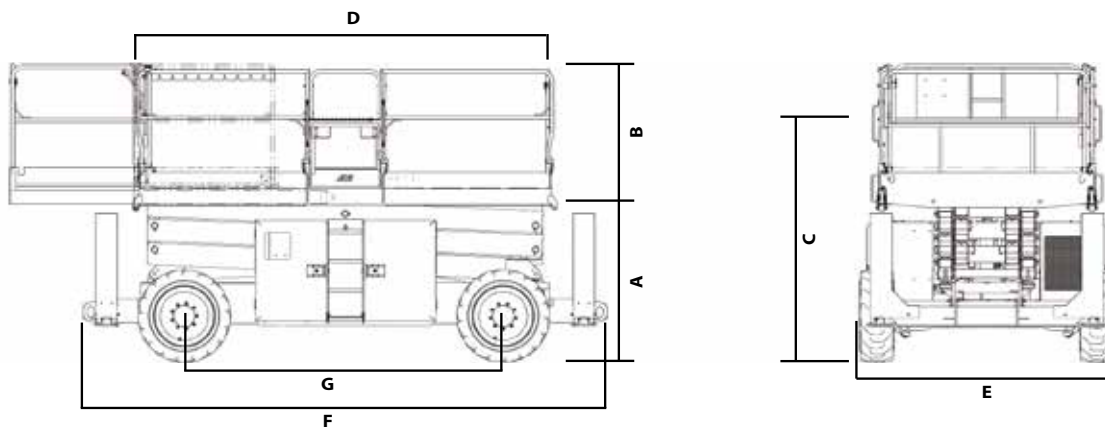

### IMPORTANT

JLG is continually researching and developing products and reserves the right to make modifications without prior notice. All data in this document is indicative. Certain options or country standards will increase weight. Specifications may change to meet country standards or with the addition of optional equipment.



### JLG EMEA BV

Polaris Avenue 63  
2132 JH Hoofddorp  
The Netherlands  
Tel: +31 (0)23 565 5665  
Fax: +31 (0)23 557 3750  
[www.jlg.com](http://www.jlg.com)

Due to continuous product improvements, JLG Industries reserves the right to make specification and/or equipment changes without prior notification.

**An Oshkosh Corporation Company**